

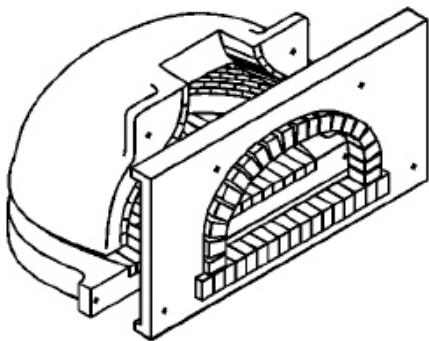

***Price list 2011( sterling prices are subject to current exchange rates, please check when ordering)***

## ***INTEGRABLE (built in) OVEN [FTGI]***



This oven is made of bricks. A small but traditional oven made for today's kitchen with a modern or rustic ambiance.

Reference: FTGI :Vault and arch made of bricks

Weight: 167 Kg Interior dimension:0,23 m<sup>2</sup>

Flue diameter:Ø155 mm Exterior dimension: Width:0,92 m

Depth:0,53 m Height:0,46 m The "Equipment" includes :

The oven, the exterior door, the flue connector and the complete insulation

It is not possible to use the insulating door or the vault thermometer with this oven

Price £1322 + VAT + shipping at cost

## ***PLEIN AIR OVEN [F700A]***

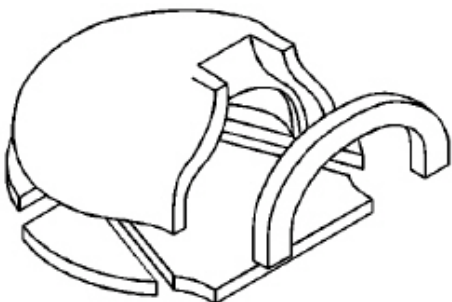

A small inexpensive 70 cm oven made of refractory concrete made for outdoor cooking. Its thickness doesn't allow it to accumulate as much temperature as the others from the range.

Reference: F700A made of refractory concrete. Weight:108 Kg

Interior dimension:0,37 m<sup>2</sup> Flue Diameter:Ø 155mm

Exterior dimension :Width:0,78 m Depth:0,83 m Height:0,36 m

Option "With Equipment" includes : the oven, the insulation

the cast iron door, the inner insulating door and the flue connector

Brick version not available

Price: £880 + VAT + shipping at cost

## **MENAGER OVEN BRICK VERSION [F700B]**

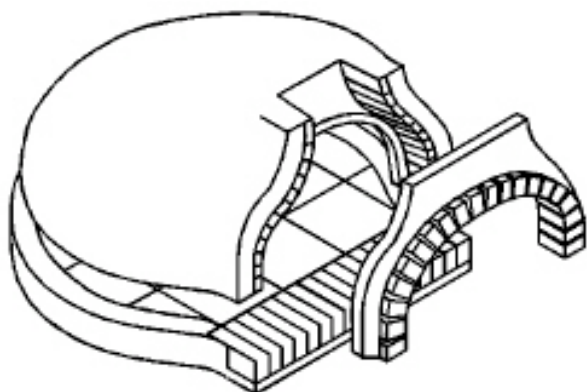

The family oven. The B version is of bricks.  
The thickness is 8 cm.

Thanks to its size, it is aimed at small families and allows you to cook everything. Pizzas, roasts, skewers, stews and bread. It cooks everything to perfection!

Reference: F700B Vault, arch and floor of bricks.

Weight: 230 Kg Interior dimension: 0,37 m<sup>2</sup>

Flue Diameter: Ø 155mm

Exterior dimension :Width: 0,86 m Depth:0,90 m

Height:0,40 m The option "with equipment" includes : The oven, the flue connector, the insulated inner door, the cast iron outer door and the complete insulation.

This oven is available at lower cost with a vault made of refractory ( chamotte) cement F700C

Price: Brick version F700B+  
raised dome F700BH+  
Chamotte version F700C+  
raised dome F700CH+

£1504 + VAT + shipping at cost

£1890 +VAT

£1280 + VAT

£1470 + VAT

## **CAMPAGNARD OVEN BRICK VERSION [F800B]**

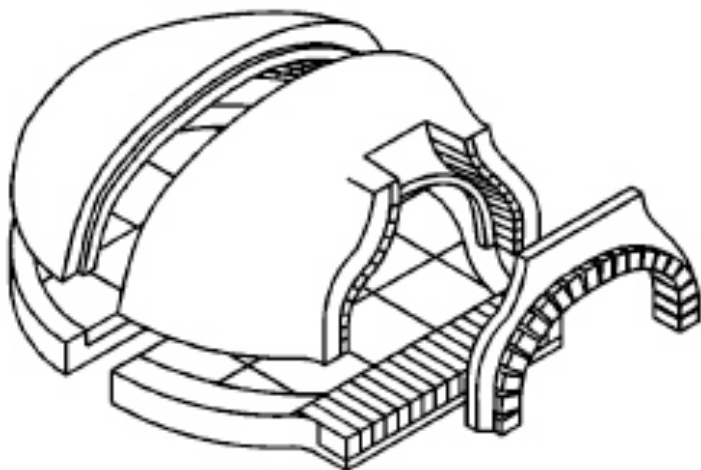

The characteristics of the vault are the same as the ones of the 700B. It is the best one for a family thanks to its size.

Reference: F800B The vault, the floor and the arch of bricks.

Weight:295 Kg

Interior dimension: 0,49 m<sup>2</sup>

Flue Diameter: Ø 155mm

Exterior dimension :

Width : 0,96 m Depth : 0,99 m Height: 0,40 m

Option "With Equipment" includes : the oven, the insulation, the cast iron door, the insulation door the flue connector

This oven is available at lower cost with a vault made of refractory ( chamotte) cement F800C

Price: Brick version F800B+  
raised dome F800BH+  
Chamotte version F800C+  
raised dome F800CH+

£1810 + VAT + shipping at cost

£2150 + VAT

£1440 + VAT

£1710 + VAT

## **GOURMET OVEN BRICK VERSION [F950B]**

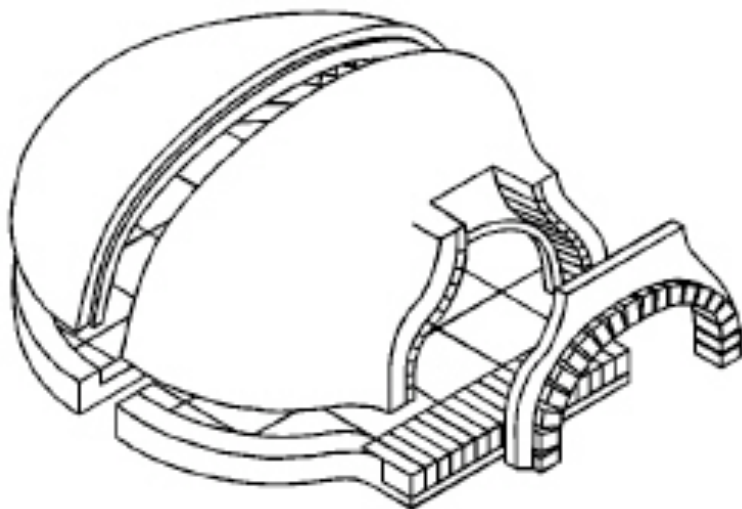

The version 950 B has a vault of bricks.  
The thickness is 8 cm.  
Floor stones can be replaced if necessary.  
The inside dimensions make the oven a favourite with large families, restaurants or caterers.  
You can bake up to 9 kg of bread.  
Reference: F950B  
The vault, the floor and the arch of bricks.  
Weight: 420 Kg Interior dimension: 0,7 m<sup>2</sup>  
Flue Diameter: Ø 155mm  
Exterior dimension: Width: 1,11 m  
Depth : 1,15 m Height: 0,40 m  
Option "With Equipment" includes : the oven, the insulation ,the cast iron door, the insulation door and the flue connector  
This oven is available at lower cost with a vault made of refractory (chamotte) cement F950C

Price: Brick version F950B+  
raised dome F950BH+  
Chamotte version F950C+  
raised dome F950CH+

£2290 + VAT + shipping at cost  
£2805 + VAT  
£1752 + VAT  
£2143 + VAT

## **COVERS FOR DOMESTIC OVENS**



This cover makes a simple, one piece, instant and watertight decoration.  
It is reinforced with Epoxy fibre glass resin  
It is possible to use it outside and use an acrylic paint to protect it.  
NB: Insulation **MUST** be placed between the oven and the cover. The flue must be double wall with insulation.



The Rain Top for the cover, AC107, is available to cap off the chimney to prevent rain entering the flue

Price: Plein Air and Menager Hood AC102  
Campagnard Hood AC103  
Gourmet Hood AC104  
Rain Top AC107

£691 + VAT  
£733 + VAT  
£791 + VAT  
£63 + VAT